

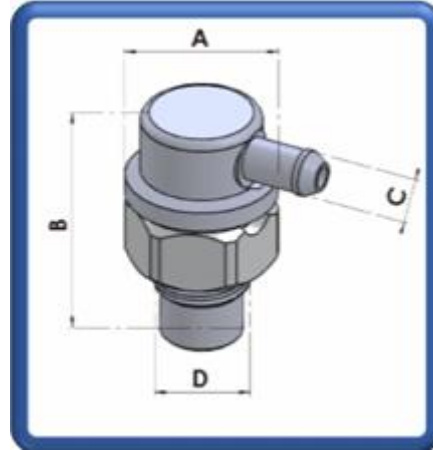

# Tank Mount Valves

Vent Valve Rollover, Tank Mount, Ø5.0 @ 90° – 5/16" UNF Thread.  
Part Number: CF-AA-041 (THV45UAV)



## Specifications:

Fixing Arrangement:

Applications:

Compatibilities:

Finish:

Weight:

Flow Capacity:

Valve Placement:

90°Ø5.0mm Standpipes (Top)

7/16" UNF Thread (Bottom)

Non-Standard "high octane fuels" Example: Jet A /B

Operation Temperature -40°C to +80°C

Anodised Silver

10.5 grams

0.6 litre/ second

Vertical ±25° (Top of Tank)

## Materials:

Bodies:

O-Ring:

Internal Floatation Ball:

Washer:

Retention:

Nut:

Aluminium Alloy 6082/T6

Viton A (FPM or FKM)

NS4 Aluminium Ball

Stainless Steel 316

Brass CZ1221

Aluminium Alloy 6063/T2

## Dimensions:

Outside Diameter A:

Height B:

Spigot Diameter C:

Thread Spec to Casing D:

17.5mm

29.0mm

Ø5.0mm Spigot

7/16" UNF Thread

## Optional('s):

**Fluid Containment – When It Matters**

Tell: +4420 8594 7990 / Fax: +4420 8594 7989 / [www.newton-equipment.com](http://www.newton-equipment.com) / [info@newton-equipment.com](mailto:info@newton-equipment.com)

Registered in England. 6 Orwell Close/ Fairview Ind. Park/ Rainham/ Essex/ RM13 8UB