

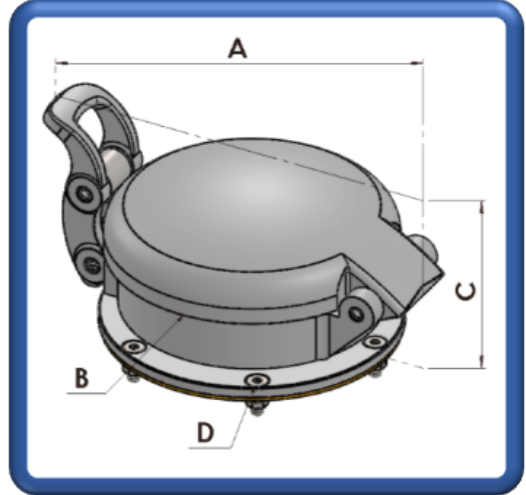

# Classic 350

**Classic 350 Fuel Filler Cap, 6 Hole Flange.  
Part Number: OM-ZA-002 (C350CHF)**



## **Specifications:**

**Options:**

**Fixing Arrangement:**

**Applications:**

**Compatibilities:**

**Finish:**

**Weight:**

**Supplied With:**

N/A

6 x M5 CSK Bolts

Fuel, Oil & Water Tanks

Compatible with Add Blue

Operation Temperature -40°C to +80°C

Natural Polished

290.0 grams

Flange

Cap

Screw Pack (CSK Screws, Washers, Nyloc Nuts)

Gasket

## **Materials:**

**Centre Cap:**

**Flange:**

**O-Ring:**

**Gasket:**

Aluminium Alloy LM25 Cast

Aluminium Alloy 6082/T6

Viton A (FPM or FKM)

NBR Cork

## **Dimensions:**

**Length A:**

**Width B:**

**Height C:**

**PCD D:**

**Bore Diameter:**

172.0mm

122.0mm

81.0mm

6 x M5 CKS Bolts on a 114.3mm PCD

89.0mm

## **Optional('s):**

***Fluid Containment – When It Matters***

Tell: +4420 8594 7990 / Fax: +4420 8594 7989 / [www.newton-equipment.com](http://www.newton-equipment.com) / [info@newton-equipment.com](mailto:info@newton-equipment.com)

Registered in England. 6 Orwell Close/ Fairview Ind. Park/ Rainham/ Essex/ RM13 8UB