

Female Valves

Options: Twin / Single
Tank Mount: Attaches directly to tank.

Tank Mounts

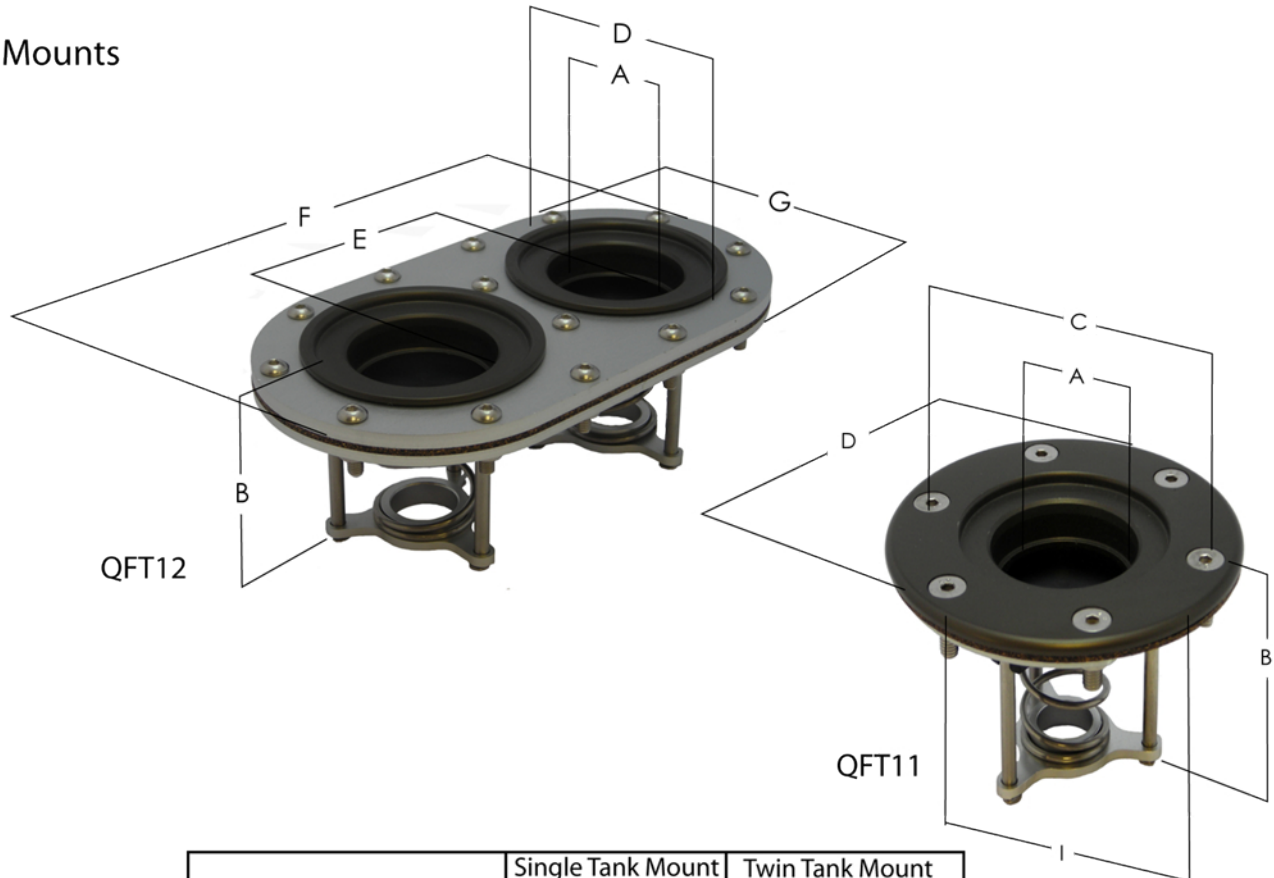

	Single Tank Mount QFT11	Twin Tank Mount QFT12
A - Aperture size	35 mm	35 mm
B - Depth	58 mm	58 mm
C - Bolt Circle	76.2 mm (3")	Not Applicable
D - Flange diameter	94 mm	63 mm
E - Pitch between Valves	Not Applicable	72 mm
F - Overall Length	Not Applicable	160 mm
G - Overall Width	Not Applicable	88 mm
H - Hose Connection	Not Applicable	Not Applicable
I - Spigot Diameter	62.5 mm	65.6 mm

In accordance with our policy of continuous improvement we reserve the right to change our products without prior notice. Please contact our Technical Office for notice of any product updates.

Fluid Containment - When It Matters

Tel: +44 (0)20 8594 7990 / Fax: +44 (0)20 8594 7989 / www.newton-equipment.com / info@newton-equipment.com

Registered in England . Ajax Works, Hertford Road, Barking, Essex, IG11 8DY, UK

© Newton Equipment 2010



1" Quick Fill Tech Specs

Female Valves

Average Filling Speed:
1L/sec (Tested with 25L water).

Remote mount:
Connects to a remote tank via a suitable hose of optional 57mm, 38 mm or 32mm diameter.

	Single Remote QFR1157	Single Remote QFR1138	Single Remote QFR1132	Twin Remote QFR1257	Twin Remote QFR1238	Twin Remote QFR1232
A - Aperture Size	35 mm	35 mm	35 mm	35 mm	35 mm	35 mm
B - Depth	58 mm	98 mm	104 mm	58 mm	97 mm	103 mm
C - Bolt Circle	76.2mm (3")	76.2mm (3")	76.2 mm (3")	Not Applicable	Not Applicable	Not Applicable
D - Flange Diameter	94 mm	94 mm	94 mm	63 mm	63 mm	63 mm
E - Pitch between Valves	Not Applicable	Not Applicable	Not Applicable	72 mm	72 mm	72 mm
F - Overall Length	Not Applicable	Not Applicable	Not Applicable	160 mm	160 mm	160 mm
G - Overall Width	Not Applicable	Not Applicable	Not Applicable	88 mm	88 mm	88 mm
H - Hose Connection	57 mm (2.25")	38 mm (1.50")	32 mm (1.25")	57 mm (2.25")	38 mm (1.50")	32 mm (1.25")
I - Spigot Diameter	62.5 mm	62.5 mm	62.5 mm	62.5 mm	62.5 mm	62.5 mm

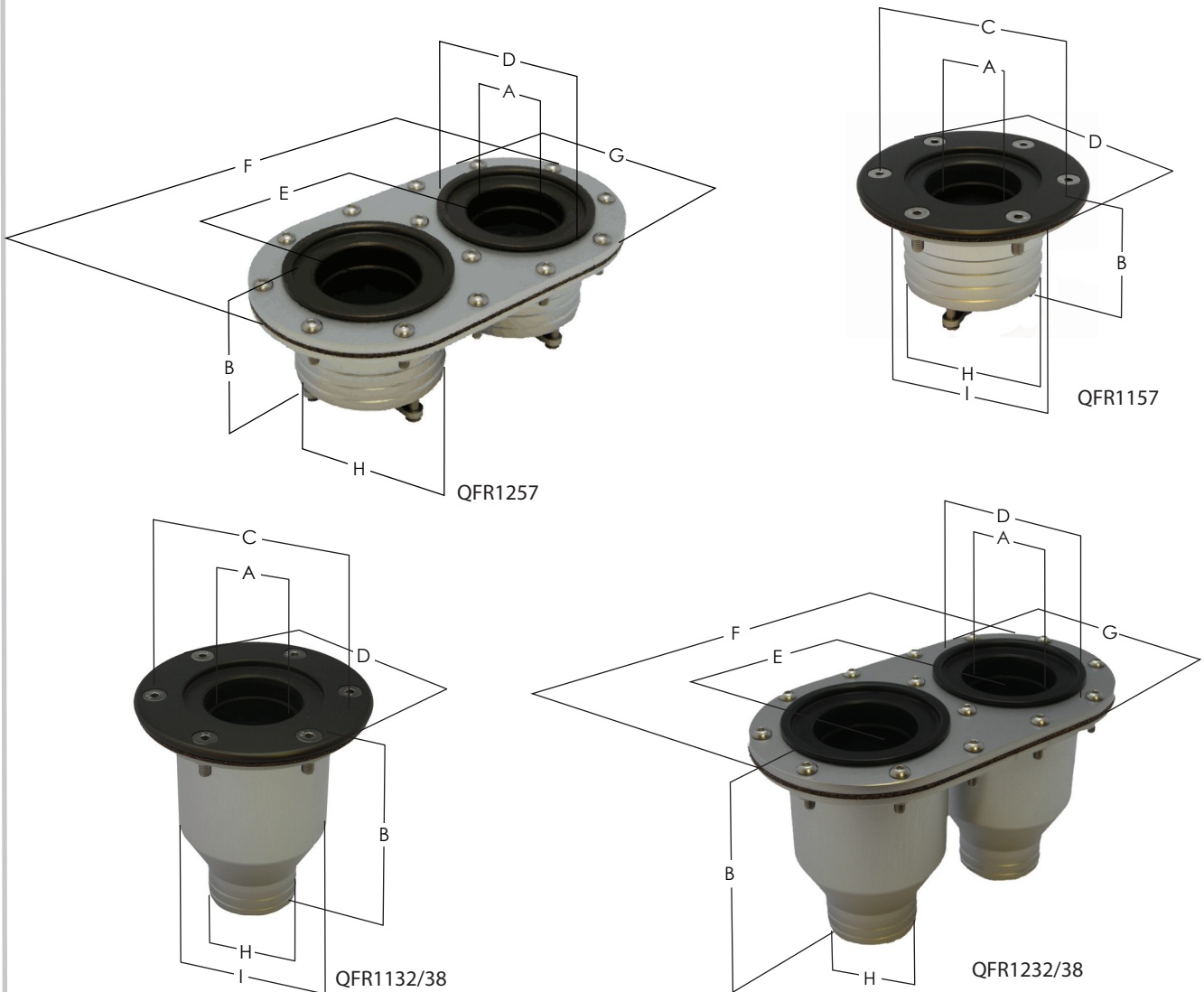

In accordance with our policy of continuous improvement we reserve the right to change our products without prior notice. Please contact our Technical Office for notice of any product updates.

Fluid Containment - When It Matters

Tel: +44 (0)20 8594 7990 / Fax: +44 (0)20 8594 7989 / www.newton-equipment.com / info@newton-equipment.com

Registered in England . Ajax Works, Hertford Road, Barking, Essex, IG11 8DY, UK